

WORKING PRINCIPLES

The grain enters from the product entrance, and the hull of the grains is peeled in the specially designed peeler. Before it is subjected to multiple processing, the grain input moisture value is measured and the dehumidification values required for the dampening process are determined. All technical values in the peeling, separating and tempering sections can be measured and changed for the product.

The water addition process required for the dampening process can be changed by measuring the input moisture value of the grain instantaneously. More than one value can be measured and the amount and speed of water required for dampening can be adjusted manually or automatically. With the special cleaning section, product ready to dampening is provided at the desired cleaning values after the peeling process.

FEATURES

- Superior peeling process efficiency
- Cleaning and separating of grain
- 20-25 tons / hour product processing capacity
- For the dampening process, up to %6 moisture effect.
(It depends on the reference grain value.)
- Instant product flow rate and moisture value measurement



Product Data Sheet

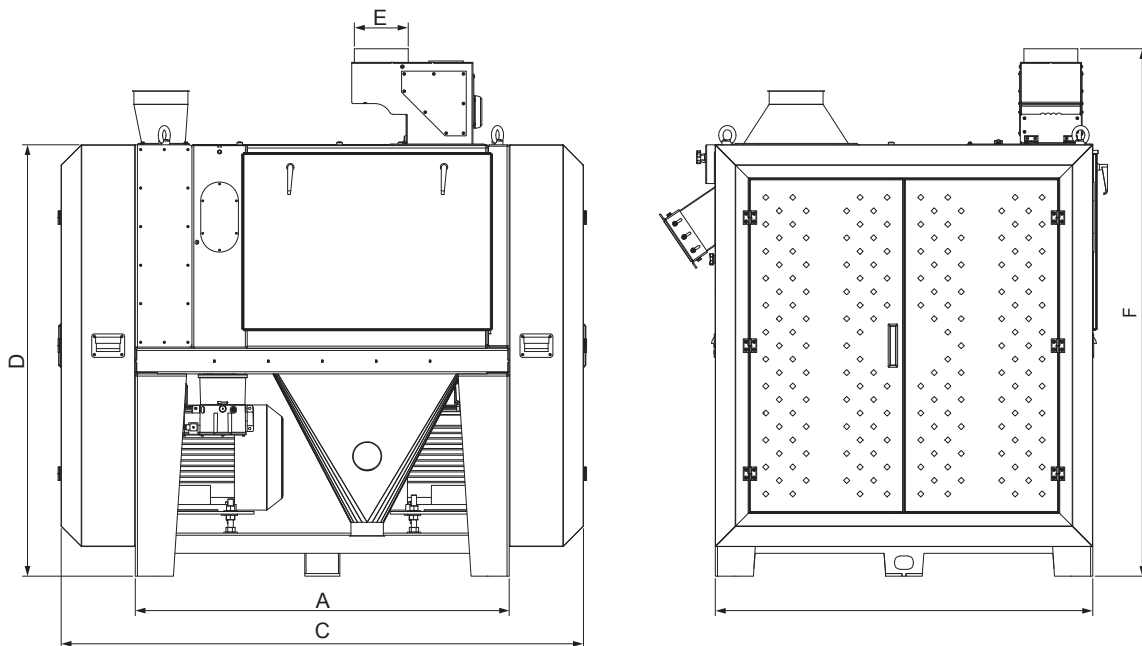

Type	Technical Features								Weight (kg)
	Capacity (t/h)	Power (kw)	A	B	C	D	ØE	F	
GDCD 400	15 - 25	22 - 18,5	1387	1400	1937	1600	200	1956	2175